



MODEL HDS-70 USE AND MAINTENANCE MANUAL

MANUFACTURED FOR: _____
SERIAL NUMBER: _____ DATE: _____



IMPORTANT: Read and understand the entire contents of this manual prior to setting up, operating, or maintaining the Stone Mason HDS70. Special attention should be paid to the safety section as well as the safety highlights located throughout this manual. Contact the factory if you do not understand anything in these instructions.

TABLE OF CONTENTS

WARRANTY	3
SAFETY GUIDELINES	4
LOCATION	7
OPERATING INSTRUCTIONS	8
SPLITTING PROCEDURE	10
FLOW CONTROL VALVE	11
TIPS FOR SPLITTING	11
TOOTH REPLACEMENT	12
CARBIDE REPLACEMENT	14
PREVENTATIVE MAINTENANCE	15
TROUBLE SHOOTING	16
PARTS LIST	16
HYDRAULIC SCHEMATIC	19
CUTTER DIMENSIONS	20
ADJUSTING THE SIDE GUIDES	21
WIPER SEAL INSTALLATION	23
RE-PACKING THE PISTON BAR	25

WELCOME!

Thank you for your purchase of the Stone Mason HDS-70

For over 50 years we have built stone cutting and material handling equipment for the Stone Mason and Quarry operation. Our fully hydraulic cutting system provides the best cutting control on the market.

Tight design tolerances, engineering excellence and manufacturing discipline, coupled with your simple routine maintenance will provide many years of productive service. Your Stone Mason is built for continuous service under harsh conditions.

We design and manufacture our machinery to be field serviceable with “off the shelf” tools and parts whenever possible. When not, we’ll provide detailed service instructions and specific tooling or parts. We also maintain a field service staff if you prefer to have us handles the job. The choice is yours.

Simply put, we make the best stone cutters on the market and offer the best prices. It’s our pleasure to provide you with this information and assure you your business is valued.

*Sincerely,
Cee-Jay Tool Company*

NOTICE

This manual and the examples in it are provided “as is” and are subject to change without notice. Cee-Jay Tool Company Inc. makes no warranty of any kind with regard to this manual, including, but not limited to the implied warranties of merchantability and fitness for a particular purpose. Cee-Jay Tool Company shall not be liable for any errors or for incidental or consequential damages in connection with the furnishing, performance, or use of this manual or the examples contained herein. All rights reserved. Reproduction, adaptation, or translation of this manual is prohibited without prior written permission of Cee-Jay Tool Company.

Cee-Jay Tool Company, Incorporated
LIMITED WARRANTY

Cee-Jay Tool Company, Incorporated (“CJT”) warrants to the original purchaser, other than a purchaser for resale (the “Purchaser”), that CJT’s stone splitting machinery shall be free from defects in materials and workmanship. For a period of one (1) year from completion of delivery, CJT will, at its sole and exclusive discretion, either replace or repair any machine or part thereof defective in workmanship or material, at no charge to the purchaser.

All warranty repairs must either be performed by or authorized by CJT. To obtain warranty service and/or approval, the purchaser must contact CJT (800-350-9313) directly.

WARRANTY LIMITATIONS:

This warranty shall remain in effect only if the machine is used and maintained in accordance with all operating instructions set forth in the manuals and instruction sheets furnished by CJT. CJT shall have no liability to repair or replace defective parts until the purchaser has fulfilled its payment obligations. No allowance will be made for repairs or alterations made without CJT’s prior written consent or approval. **CJT is the only authorized party that can repair, or order the repair of, the machinery.**

This warranty becomes null and void if (1) the Purchaser or Purchaser’s agents make any changes, modifications, alterations or additions, of any kind, to the stone splitting machinery, (2) if Purchaser or Purchaser’s agents physically damage the machinery from either accidental or intentional misuse, and/or (3) if Purchaser or Purchaser’s agents repair or attempt repair of the machinery either by themselves, or through or by an unauthorized repair person *during the warranty period.*

The limited warranty provided by CJT excludes the following:

1. Damage, malfunction or failure caused by or resulting from improper maintenance, misuse, neglect, accident or any other cause beyond the control of CJT.
2. Paint, batteries, filters, fluids, light bulbs, tires, cutting teeth or any commonly expendable item (this warranty excludes claims of a ‘wear and tear’ nature).
3. Damage to machines and/or components while being transported from CJT’s facility to your destination.
4. Accessories or peripherals not manufactured by CJT, which shall be subject only to whatever warranty that is supplied by the manufacturer of such component/product.

No person, agent, distributor, dealer or company is authorized to change, modify or amend the terms of this Limited Warranty in any manner. CJT makes no warranties, guarantees or representations, express or implied with respect to the machine tool, or parts thereof, except to the extent such warranty is set forth herein. The equipment covered does not necessarily comply with any codes or standards unless specifically quoted, ordered and so accepted.

THIS WARRANTY IS IN LIEU OF ALL OTHER WARRANTIES, EXPRESS OR IMPLIED, INCLUDING WITHOUT LIMITATION WARRANTIES OF MERCHANTABILITY OR FITNESS FOR ANY PARTICULAR USE OR PURPOSE. CJT’S LIABILITY UNDER THIS WARRANTY IS EXPRESSLY LIMITED TO ITS PROMISE TO REPAIR OR REPLACE THE DEFECTIVE GOODS. CJT SHALL HAVE NO FURTHER LIABILITY IN CONTRACT OR NEGLIGENCE OR UNDER ANY THEORY OF LAW OR EQUITY FOR ANY DAMAGES, DIRECT OR INDIRECT, INCIDENTAL, SPECIAL OR CONSEQUENTIAL, OR ANY DELAY RESULTING FROM THE DEFECT.

SAFETY GUIDELINES:

Cee-Jay Tool Company recognizes that the safe operation of the Stone Mason HDS-70 is the most important responsibility shared by management and employees. This section of the manual is intended as a guide for those who operate, service, and supervise the operation of the Stone Mason HDS-70. It is not intended to be a safety code. Our purpose is to alert operators, service personnel and supervisors to the importance of establishing safe operating and maintenance procedures.

Read and understand these guidelines before attempting to install, operate, or service the Stone Mason HDS-70. Failure to observe these guidelines may cause serious injury or death.

The Stone Mason HDS-70 is a semi-portable cutter that will require the use of a forklift or other type of suitable lifting machinery. This cutter has two lifting points cut into the bottom of the frame intended for the forks of a lift. The forks should be extended all the way through the bale of the frame so that the out bound table of the cutter is touching the mast of the forklift. This machine weighs approximately 5000 pounds so a suitable forklift is required. Before moving the cutter be certain to disconnect the three hydraulic hoses that connect the power unit to the unit.

CAUTION

Always operate the machine on flat and level ground.

The Stone Mason HDS-70 is top heavy. Always locate the cutter and the accompanying power unit on a hard flat surface. Be certain that all 3 hydraulic hoses are properly connected between the cutter and the power unit before starting the engine or electric motor on the power unit.

CAUTION

Never place your hand or any other part of your body into the splitting area of the Stone Mason HDS-70 unless the main power supply has been disconnected and "Locked and Tagged."

The Stone Mason HDS-70 uses very high pressure and forces to execute a split. This splitting process will severely injure persons who do not recognize this danger. The power unit should be turned off and the power locked and tagged according to OSHA and EMSHA regulations prior to reaching into the jaw area.

Do not let the desire for increased production overcome the essential need for safety. Failure to follow this simple rule can result in serious bodily injury or death.

CAUTION

Never expose any part of the body to a high pressure leak in the hydraulic system.

The hydraulic system is under high pressure and high pressure fluids can be injected into the body if proper precautions are not taken. Do not use your bare hands to feel for hose leaks along hoses.

CAUTION

Always wear proper protective clothing when operating the Stone Mason HDS70.

Eye Protection: Splitting stone can produce splinters of stone that can harm the unprotected eye. All personnel operating or working near the Stone Mason HDS-70 should wear safety glasses with side shields. Some stone splits with a force that warrants additional protective measures such as full face shields or other protective clothing.

Hand Protection: The splitting process can produce a number of razor sharp edges that can seriously injure the unprotected hand. All operators should wear a good pair of protective gloves.

Foot Protection: Whenever split stone is handled, the risk of a serious foot injury exists. Safety- toe shoes should be worn by all operators to protect against falling stone.

Ear Protection: Hearing protection may be necessary depending on the power unit as well as the work environment. Contact your local health official for specifics on required levels of hearing protection.

CAUTION

The Stone Mason HDS70 as well as the area around it should be kept free of debris at all times.

The Stone Mason HDS-70 can produce a large amount of debris in the course of a day, both on the machine and around the machine. Some means should be devised to remove the stone chips from the area.

The rollers and splitting area should be kept clear of stone fragments at all times. We recommend using a broom or long handled brush to remove stone fragments from the tooth area. Do not remove these fragments with your hands without first turning off the power unit. Operating the Stone Mason HDS-70 with stone fragments piled up under the teeth can result in machine damage or personal injury.

The area around the Stone Mason HDS-70 should be kept clear to reduce the risk of tripping.

CAUTION

Never remove or deface any placard or decal that instructs the operator or others of safety precautions.

The Stone Mason HDS-70 was shipped from the factory with certain warning placards in place. These placards provide information critical to the safe and efficient operation of the splitter and should not be removed, covered, or defaced. If replacement signs are needed, contact the factory.

CAUTION

Inspect all hydraulic hoses and connections daily for leaks or damage.

The hydraulic system is designed for up to 2500 psi of operating pressure. When a leak occurs with fluids under this kind of pressure, a serious hazard exists. All worn or damaged fittings and hoses should be replaced immediately.

CAUTION

Only qualified technicians should be allowed to make adjustments to or perform service on the hydraulic system.

The Stone Mason HDS-70 has been shipped from the factory with the pressure relief valves set for optimal operation. Altering these adjustments can severely damage the splitter and or cause serious bodily injury. Altering the pressure settings on the pressure relief valves will void the manufacturers' warranty.

CAUTION

Improper lifting or moving of this equipment can result in personal injury and equipment damage.

The Stone Mason HDS-70 is top heavy and prone to tip over if caution is not exercised whenever the splitter is moved. If it will be moved over uneven surfaces then it should be chained to the mast of the forklift.

Arrangements can be made to have a factory representative come to your site and assist in setting the machine up and training personnel in the proper use of the splitter.

If at any time you encounter problems or have questions please contact the factory directly at 1-800-350-9313.

LOCATION:

Before your Stone Mason is set up at your job site, how and where it will be positioned should be determined.

Permanent Installation: The Stone Mason will be placed in a permanent location and the stone will always be brought to the splitter. A level reinforced concrete pad or foundation capable of supporting 8000 pounds should be designed and constructed. It may be desirable to have concrete pads under each of the legs of any additional conveyors as well.

Mobile Installation: If the Stone Mason will be moved frequently from place to place, always locate it on a hard level surface. Disconnect the hydraulic hoses that connect the unit to its accompanying power supply. Reconnect the hoses prior to starting the power unit.

CAUTION

An excessive slope on the inbound conveyor could cause stone to roll in an uncontrolled manner causing equipment damage or serious personal injury.

GASOLINE ENGINE INSTALLATIONS:

If a gasoline or diesel engine powers the hydraulic power unit it will be necessary to fill the fuel reservoir. Consult the literature provided for your specific engine to review starting, break in and maintenance procedures.

CAUTION

Never remove any guards or enclosures while the engine is running. Moving parts can cause serious injury.

CAUTION

Never add fuel to a running engine. Hot engine surfaces and sparks produced from the engine are possible sources of ignition.

CAUTION

Never service the engine when the splitter is operating.

CAUTION

If an engine is used in an enclosed area some means of exhausting the engine will be necessary. Inhalation of exhaust gases will result in serious illness or death.

CAUTION

Hot exhaust surfaces may cause personal injury.

OPERATING INSTRUCTIONS: Be sure to read the section on safety prior to operating the Stone Mason HDS-70. Before starting the hydraulic power pack be sure to check all fluid levels. The oil sight gage on the side of the hydraulic tank has a black mark near the top and a red mark near the bottom. The oil level in the tank should remain between these two lines at all times. The unit is powered by a gas engine be sure to check the engine oil level using the dipstick located on the right side of the engine.

Start the power pack by following the start up procedures in the manual for your specific engine. Let the pump circulate the hydraulic oil for a few minutes prior to operating the splitter.

CAUTION:

The working parts of the hydraulic power pack may get hot when in use. DO NOT TOUCH.

Handles #1 & #2 are located together at the back of the machine next to the Inbound Table. They control the Top Jaw height, the Inbound Table height, and the Teeth (Chisel) hydraulics.

Handle #1:

Forward- raises Top Jaw.

Back – lowers Top Jaw.

Handle #2:

Forward – unlocks teeth and raises the Inbound Table. Also called detent position.

Back – locks teeth and lowers the Inbound Table.

Note: Handle #2 has a detent that holds the handle in the forward position until it is manually returned to the neutral position.

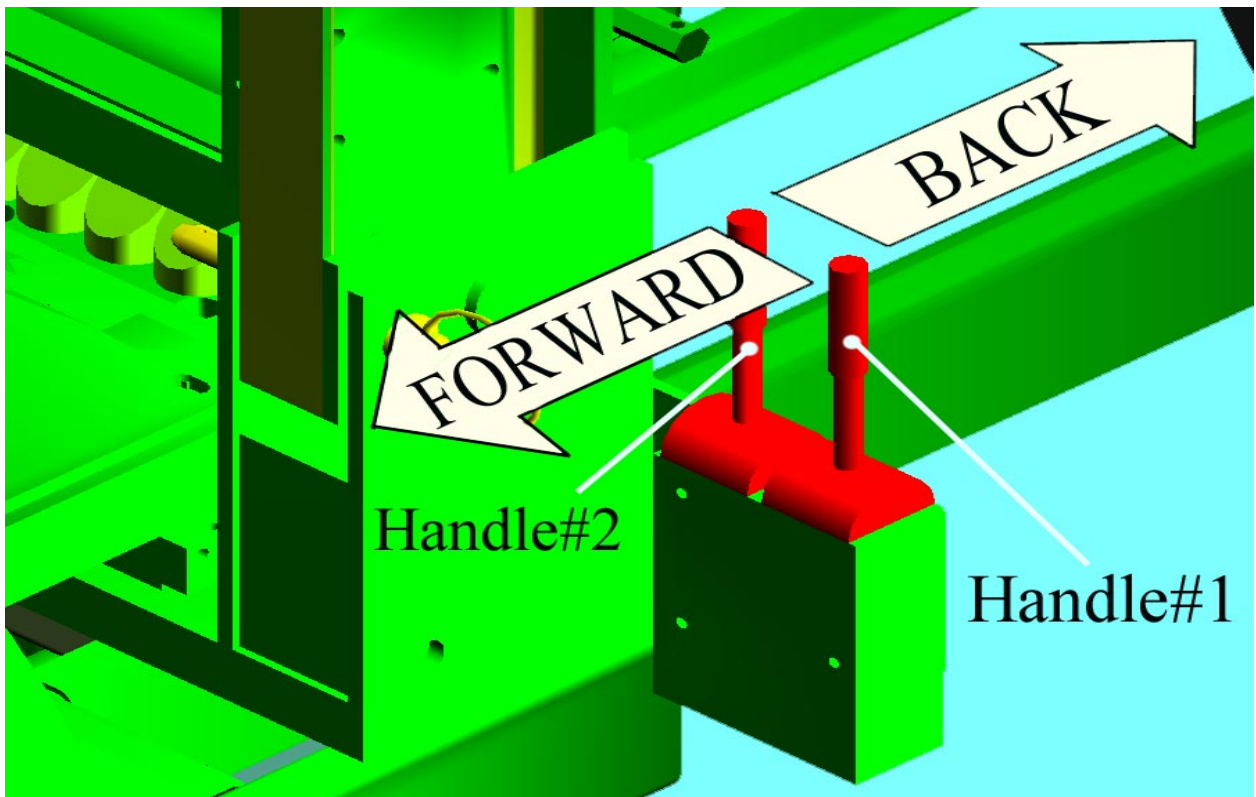

SPLITTING PROCEDURE: The following steps are the general steps taken to split stone. These steps may vary depending upon the stone and the experience of the operator.

CAUTION:

Always wear safety glasses and protective clothing to protect against splintering stone.

- 1- Raise the upper jaw far enough to get the stone into the machine. (Handle #1 Up) NOTE: There is no advantage to raising the jaw all the way up for every cut. This will only cut down on efficiency. Raise the jaw only as high as needed to insert the piece of stone into the cutter
- 2- Extend the teeth and raise the inbound table. (Handle #2 Up in the Detent Position).
- 3- Insert the stone to the desired depth while keeping the inbound table raised. If the control valve is equipped with a detent kit then the inbound table will remain raised until the handle is pulled to the neutral position. If the operator does not want to engage the detent feature of the valve then do not push the handle all the way forward. In this case the handle will return to the neutral position as soon as the operator lets go of the handle and the inbound table will return to the lower position. Always raise the inbound table prior to moving the stone into the splitter so as to prevent the stone from dragging across the bottom teeth. The edge of the lower teeth will show premature wear if the stone is allowed to drag across them.
- 4- Release Handle #2 used in step 3 to return the in-bound table to the lower position. If the detent feature was used then the operator will need to manually pull back on the lever to return it to the neutral position.
- 5- Pull Handle #1 down to lower the upper jaw until all of the teeth come into contact with the stone. The upper and lower teeth will retract into the upper and lower jaws as the upper jaw is lowered onto the stone. Do not allow any of the teeth to be pushed all the way into the upper or lower jaw. Always leave at least 1/8 inch of clearance between the head of the tooth and the jaw.
- 6- Lock the teeth in place by pulling handle #2 down. Handle #2 will return to the neutral position.

CAUTION:

Failure to lock the teeth in place prior to splitting the stone will seriously damage the splitter.

7- Pull Handle #1 down to bring the upper jaw down to split the stone. Start at step one to begin the next split.

It sounds a little complicated at first but eventually you will see that there is a rhythm to the cutting procedure:

Handle #1 Up, Handle #2 Up, Handle #1 Down, Handle #2 Down, Handle #1 Down .

FLOW CONTROL VALVE: The flow return valve pictured regulates the rate of flow of the hydraulic oil back to the hydraulic tank for the inbound table which in turn regulates the speed which it returns to the neutral position. The oil supporting each tooth also flows through this valve when the teeth are being pushed up into the jaw beam during the equalization cycle. This valve also allows the operator to adjust the splitter to account for different viscosities of hydraulic oil. **Do NOT close this valve all the way.**

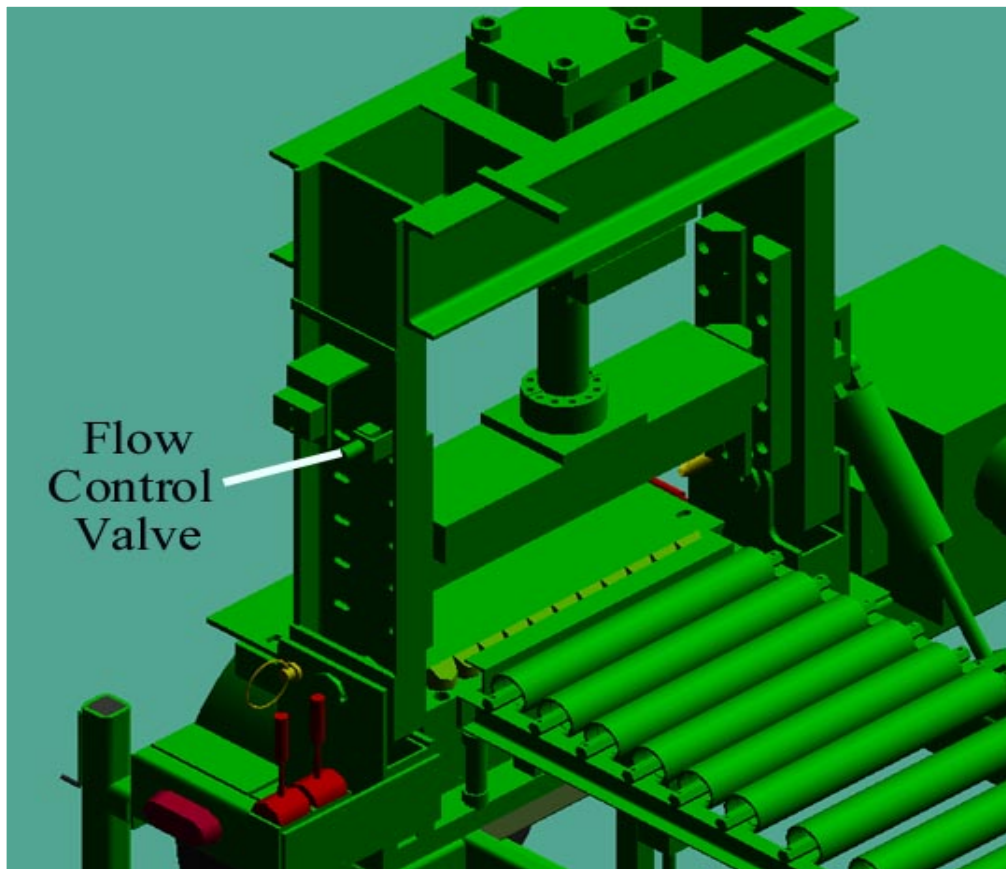

TIPS FOR SPLITTING: Every type of stone splits differently and experience is the best teacher. We can only offer general guidelines for stone splitting.

- Whenever possible try to split with the grain of the stone. Although it is possible to split against the grain, the best split quality is obtained when splitting with the grain.

- Remove loose rock and other debris from the stone prior to splitting. Loose layers of stone stacked on top of each other will not split properly.
- Bring the top jaw down on the stone so that as many teeth as possible are in contact with the stone.
- Place the flat side down. Although both the top and bottom teeth will equalize one inch, placing the flat side down makes it easier to ensure that as many teeth as possible are in contact with the stone because the top jaw can be seen by the operator. Placing the flat side down also makes it easier to roll the stone on the conveyors.
- To improve efficiency only move the upper jaw up as far as is needed to get the next piece of stone into the Stone Mason HDS70 to be split. Moving the upper jaw too far up can be a waste of time.
- When splitting fieldstone or other irregular shaped stone, let the teeth equalize up into the jaw beam as far as possible. This will help support the teeth on difficult splits.
- When splitting thin or weak stone, do not lower the top jaw onto the stone at full speed. The stone will most likely break before the split is made. To avoid this, bring the top jaw down onto the stone slowly by letting up on the control lever.

TOOTH REPLACEMENT: It may become necessary to replace a tooth at some time. The following will describe the necessary steps.

- 1- Thoroughly clean the area around the tooth that is to be removed.
- 2- Raise the top jaw up at least 8 inches from the bottom position.
- 3- Remove the retaining bolt located directly inline with the tooth that is to be removed.
- 4- Slide the tooth out of the jaw beam.
- 5- Examine the wiper inside the jaw beam and replace it if it is worn.
- 6- Wipe out the top portion of the tooth hole down to the wiper.

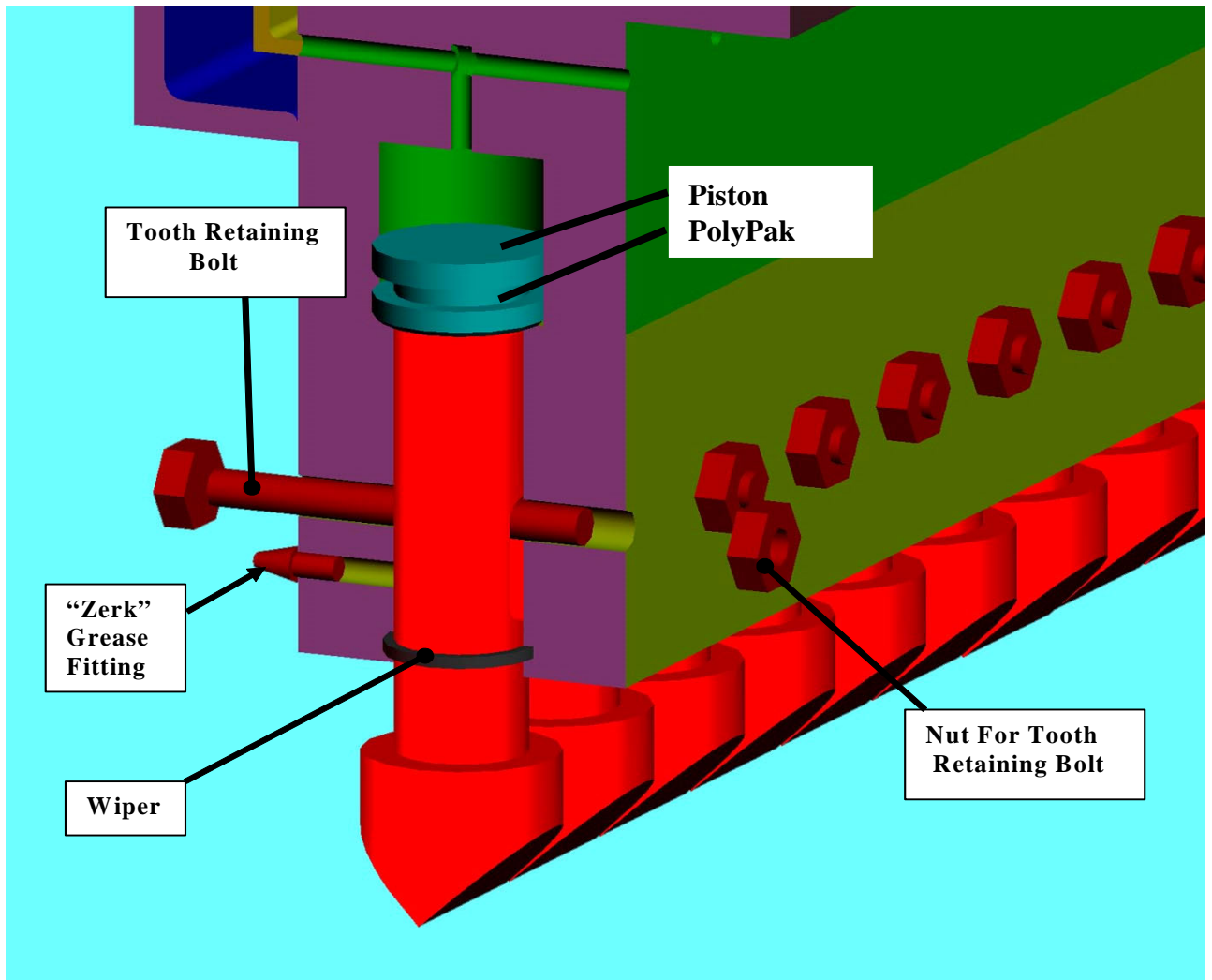

Clean the replacement tooth making sure there is no debris on the shank of the tooth.

7. Insert the replacement tooth into the hole in the jaw beam. In temperatures below 40 degrees Fahrenheit it may be difficult getting the tooth past the wiper. Be sure the new tooth lines up with the other teeth.
8. Replace the retaining bolt and torque the top lock nut to 90 ft-lbs.
9. Extend the teeth and lock them
10. Grease the new tooth prior to using.

CARBIDE INSTALLATION

- 1) Remove any carbide remaining in the tooth by heating it with a torch to break the bond of the glue. Do not over heat the tooth because this will remove the temper on the tooth and cause it to develop stress cracks and break. This will only take a few minutes.
- 2) Remove any glue from the corners of the groove with a file, a wire brush, etc. We sand blast the groove. Any remaining material will cause a weak bond and point loading on the carbide which will either cause the carbide to fracture or fall out.
- 3) The bottom edge of the carbide should be rounded slightly to reduce the chance of

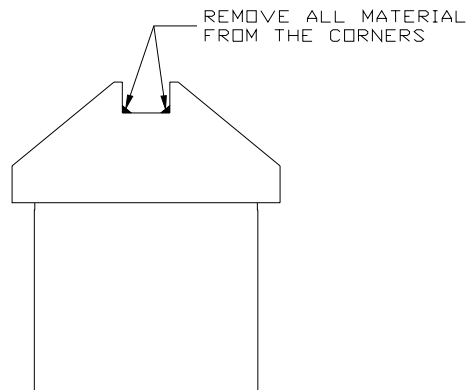

point loading. This can be done on a grinder with a green wheel installed. (Green wheel stones are used to grind carbide.) Cee-Jay Tool Company sends out carbide pre-ground.

- 4) Roughen the groove with sandpaper and remove any grease and rust with Acetone.

TEMPERATURE FOR STEP 5 IS VERY IMPORTANT. IF THE TOOTH HAS ANY "COLD FEEL" TO IT, IT MUST BE WARMED TO AT LEAST 80 DEGREES (AT CEE-JAY TOOL WE RUN HOT WATER ON THE TOOTH TO MAKE SURE THE EPOXY IS GOING TO WORK WELL.)

- 5) Mix the 2 part JB Weld thoroughly. Spread the epoxy on the bottom and sides of both the carbide and the tooth groove, and let it cure under medium clamping pressure for a minimum of 15 hours (24 hours is preferred) in a heated area no less than 55° F.

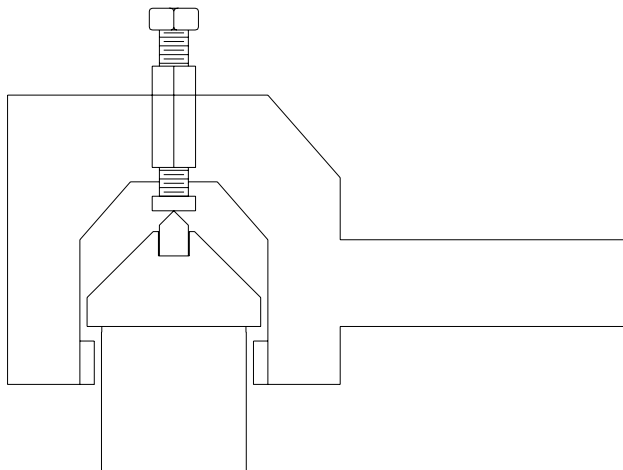

PREVENTATIVE MAINTENANCE: Proper maintenance will extend the life of the Stone Mason HDS-70 and result in lower overall operating costs. The following chart describes recommended maintenance items and intervals:

Greasing the teeth is the single most important maintenance item on the Stone Mason. **Prior to greasing the teeth, extend and lock them.** The grease lubricates the teeth and helps prevent sand and other abrasive material from getting into the jaw. Failure to grease the teeth will damage the splitter and void the manufacturers' warranty. Wipe away any excess grease to avoid getting the grease on any stone product.

The hydraulic system has a return line filter on the tank. Use replacement element Schroeder 9VZ10. This is very important for the life of your pump and seals.

If additional hydraulic oil is needed use Conoco Super Hydraulic Oil 46 or some other equivalent ISO Viscosity Grade 46 hydraulic oil.

Refer to the following chart for maintenance items and intervals.

Interval	Item	Qty
Hourly	Cleanliness around jaws and teeth. Brush off debris during operation as required to maintain long life of the jaw.	-
Daily	Check engine oil level. Add oil according to engine manual.	1
Daily	Check engine coolant level. Add more if necessary.	1
Daily	Inspect all hydraulic hoses & fittings for leaks. Add extra hose protection as required to minimize wear areas. Tighten fittings.	-
Daily	Check hydraulic oil level on sight glass on side of hydraulic tank.	1
Daily	Grease the teeth. This is the most important item for the life of your cutter!	22
Daily	Check for cracked or broken carbide (if applicable). Replace the carbide or tooth before the tooth shank is damaged.	22
Weekly	Air cleaner on engine. Clean or replace as necessary. This is very important to the long life of your engine in a dusty environment.	1
Weekly	Grease the side guides. Tighten them as required. This will prevent the cylinder rod and coupler from breaking.	8
Semi-Annual	Apply a single shot of grease to electric motor bearings.	2
Semi-Annual	Check the condition of the hydraulic oil for dark color, contamination, water floating on top. Call Cee-Jay for more info.	-
Semi-Annual	Replace hydraulic oil filter. Check the condition of hydraulic system.	-
Semi-Annual	Check the fuel filter. Replace as required.	1

TROUBLESHOOTING:

Situation	Reason	Solution
The inbound table will not lift the larger pieces of stone above the bottom teeth.	The flow control valve is open too far and not allowing enough pressure to build up in the hydraulic system to create enough force to lift the stone.	Close the flow control valve until the inbound table will lift the stone Above the bottom teeth.
On the extend teeth cycle, the teeth extending too slowly.	The flow control valve is open too far and allowing too much oil to return back to the tank.	Close the flow control valve until the teeth extend at an acceptable speed.
When the hydraulic oil heats up, the inbound table gets weaker.	The viscosity of the oil goes up with temperature.	Close the flow control valve until the situation is corrected.
When cutting thin or weak stone, the stone breaks before the teeth fully equalize.	The flow control valve is closed too far and not allowing the oil to return from the teeth back to the tank	Open the flow control valve up until the teeth equalize without breaking the stone. refer to "Tips for splitting"
When the hydraulic oil is cold, the teeth seem to be stiff and do not equalize as easily as when the oil is warm.	The viscosity of the oil goes down with temperature.	Open the flow control valve up to allow the lower viscosity oil to return to the tank.
The inbound table stays in the up position and does not lower during the split cycle	The flow control valve is closed too far and not allowing the oil to return back to the tank	Open the flow control valve up to allow the inbound table to return to the neutral position.
A tooth is stuck and will not extend after a cut is made.	The tooth bar needs to be cleaned and greased more often to prevent contamination	Close the flow control valve all the way and extend the teeth. Then reopen the control valve to it's previous setting

HDS-70 Parts List

Part No.

Description

HYDRAULIC PARTS

37-70017	Pump, Permco P124, Kubota and 25hp Electric
37-70020	Pump, Barnes, Hi-Lo, Subaru Gas Engine Only
32-86360	Lever Handle, SD-18 Control Valve
32-86070	Lever Pivot Box, SD-18 Control Valve
30-30001	Filter, Hydraulic Tank, Schroeder 9VZ10
30-75050	Filler/Breather Cap, Hydraulic Tank
30-75060	Sight Gauge, Hydraulic Oil w/Thermostat
30-50000	Gauge, Pressure, 3000psi

Part No.

Description

REXROTH CYLINDERS

50-40001	Cylinder, 8" Bore, 10" Stroke
50-40002	Cylinder, 8" Bore, 16" Stroke
34-20060	Rod Seal Kit for 8" Bore Cylinders
34-20070	Piston Seal Kit for 8" Bore Cylinders

SUBARU GAS ENGINE PARTS

64-60077	Filter, Air, Outer, Donaldson, Subaru Gas Engine
64-60079	Filter, Air, Inner, Donaldson, Subaru Gas Engine
64-60020	Filter, Oil, Subaru Gas Engine
64-60025	Filter, Fuel, Subaru Gas Engine
64-60000	Engine, 25 H.P. Robins/Subaru EH72
64-97114	Bell Housing, Subaru Engine, Magnalloy, E644602A
64-97118	Coupler, Magnalloy, Barnes Pump, M40002006
64-97115	Coupler, Subaru Engine, Magnalloy, M40010408
64-97037	Insert, Magnalloy, M470-H5

KUBOTA DIESEL ENGINE PARTS

64-50010	Filter, Air, Kubota Diesel Engine
64-50020	Filter, Oil, Kubota Diesel Engine, B161-S
64-50025	Filter, Fuel, Kubota Diesel Engine

TABLE PARTS

A20027	Roller, 3.5"OD X 24" with Bearings
A20030	Axle, Hex 1-1/16" X 26" for above roller
63-40681	Roller Assembly, 2.5"OD X 4" with Bearings and Axle
39-20027	Cylinder, In-Bound Table, 2"bore X 4"stroke
60-10320	Spring, In-bound Table

JAW ASSEMBLY PARTS

A40504	Bolt On Bottom Jaw Assembly
A5055	Top Jaw Assembly
A5045	Tooth Bar, Top
A5216	Tooth Bar, Bottom
A5022	Camshaft, 2.25" Teeth, HDS
36-00300	Cam Pin Spring
36-00200	Ball Tee
36-987687	3/8" Steel Ball
36-00100	Cam Locking Pin
34-11030	Piston Seal, PolyPak 25001500
34-11010	Dirt Wiper Seal, Small Tooth, Polypak 12501500
TOOTH-20753	Tooth, 2-1/4", w/Carbide Insert/JB Welded
TOOTH-20298	Tooth, 2-1/4", Tool Steel
56-11030	Carbide Insert, 2-1/4" BC-15

CEE-JAY TOOL COMPANY, INC.
M50 AND HDS BOTTOM JAW PARTS BREAKDOWN
CALL 1-877-962-9594 FOR PARTS

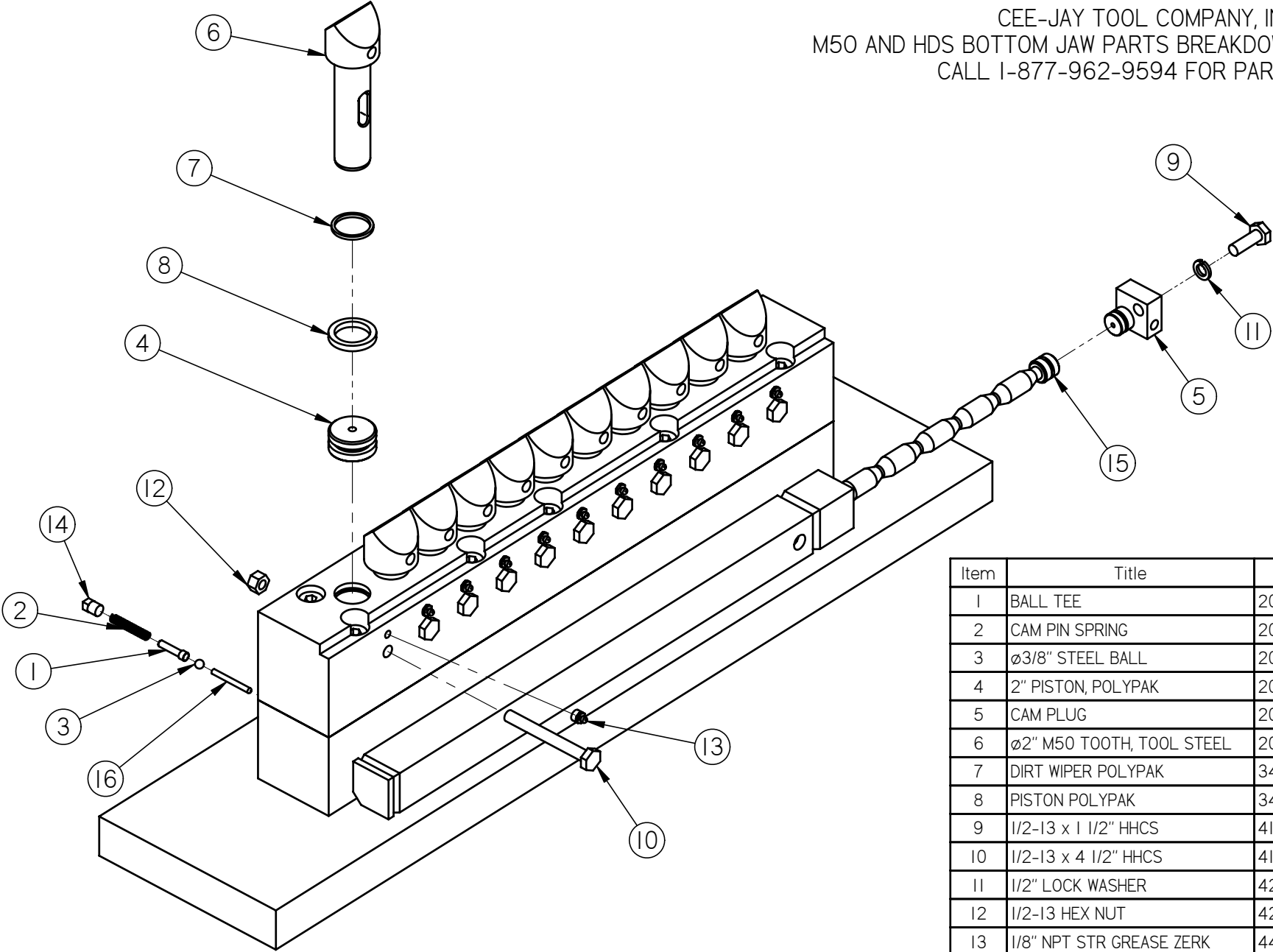

Item	Title	Part #
1	BALL TEE	20292
2	CAM PIN SPRING	20293
3	Ø3/8" STEEL BALL	20294
4	2" PISTON, POLYPAK	20296
5	CAM PLUG	20297
6	Ø2" M50 TOOTH, TOOL STEEL	20298
7	DIRT WIPER POLYPAK	34-11010
8	PISTON POLYPAK	34-11030
9	1/2-13 x 1 1/2" HHCS	41-13209
10	1/2-13 x 4 1/2" HHCS	41-13221
11	1/2" LOCK WASHER	42-33626
12	1/2-13 HEX NUT	42-36310
13	1/8" NPT STR GREASE ZERK	44-60102
14	1/4 NPT SQ HEAD PLUG	44-66371
15	CAMSHAFT	5022
16	CAM LOCKING PIN	5141

NOTES:

A NOTE ON READING THIS DRAWING:
 ALL XXXX-XXX CODES ARE SUN HYDRAULIC CARTRIDGE MODEL CODES.
 THE PORTS ARE NOT INTERCHANGABLE WITH OTHER MANUFACTURERS.
 CEE-JAY TOOL PART NUMBERS ARE LABELED AS CJ# XX-XXXX.

USE ISO VISCOSITY GRADE 46 HYDRAULIC OIL.

HYDRAULIC TANK PARTS
 FILLER/BREATHER CAP: CJ# 30-75020
 SIGHT GLASS TEMPERATURE GAUGE: CJ# 30-75060
 1/4"NPT 3000PSI PRESSURE GAUGE: CJ# 30-50000

TOOTH PARTS
 PISTONS: CJ#
 PISTON SEALS: CJ#
 TOOTH DIRT WIPERS: CJ#
 TOOL STEEL TEETH: CJ#
 TOOTH WITH CARBIDE INSERT: CJ#
 CARBIDE INSERT, CA-11, BC-15: CJ#
 CARBIDE INSERT, DO-70, BC-22: CJ#

REVISIONS			
REV.	DESCRIPTION	DATE	APR
A	INITIAL RELEASE	11/04/04	GNH

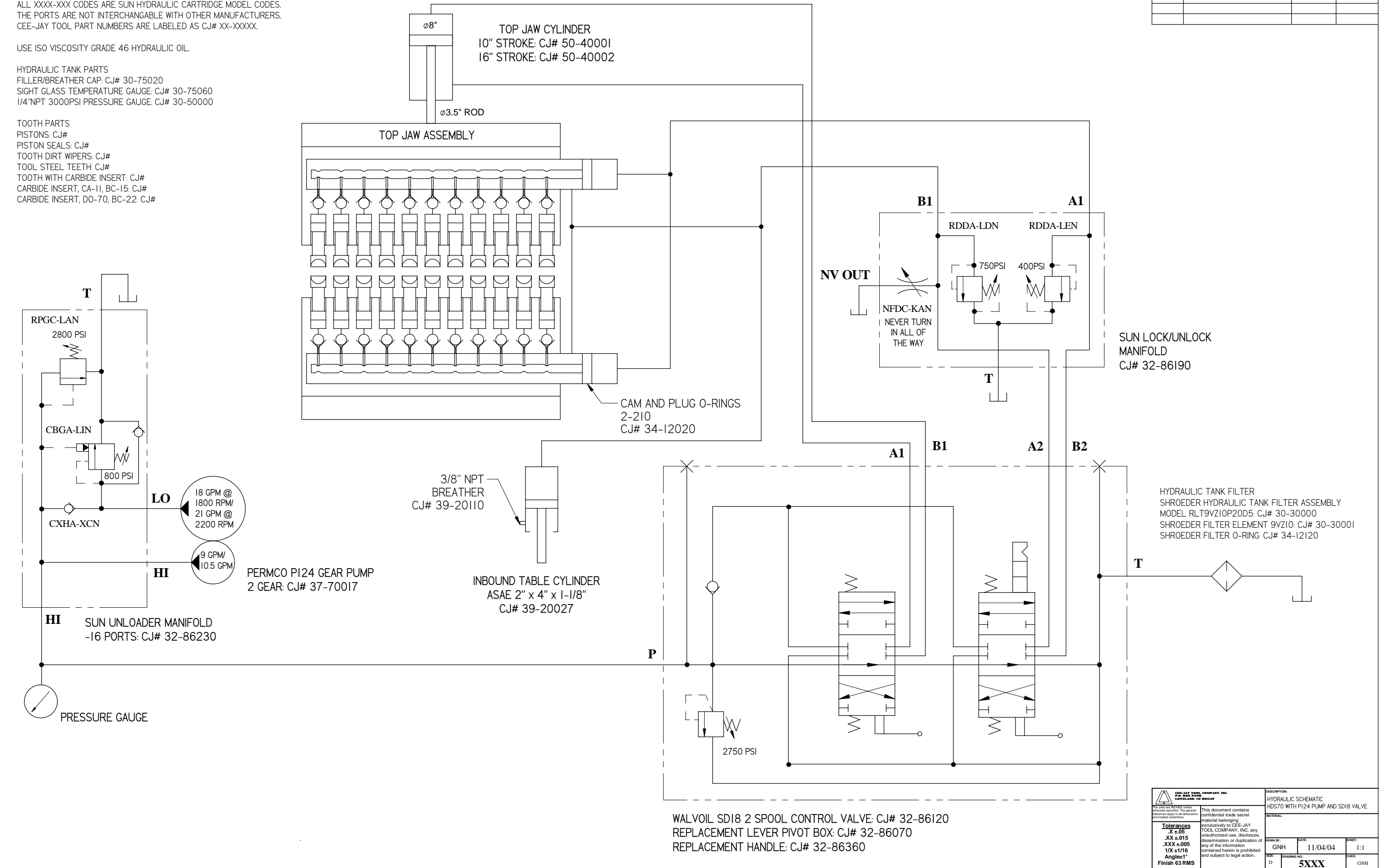

WALVOIL SD18 2 SPOOL CONTROL VALVE: CJ# 32-86120
 REPLACEMENT LEVER PIVOT BOX: CJ# 32-86070
 REPLACEMENT HANDLE: CJ# 32-86360

<p>ALL RIGHTS RESERVED. This document contains confidential trade secret material belonging exclusively to CEE-JAY TOOL COMPANY, INC. any unauthorized use, disclosure, dissemination or duplication of any of the information contained herein is prohibited and subject to legal action.</p>	DESCRIPTION: HYDRAULIC SCHEMATIC HDS70 WITH P124 PUMP AND SD18 VALVE	
	TOLERANCES: .X ±.05 .XX ±.015 .XXX ±.005 1/X ±1/16 Angles 1° Finish 63 RMS	DRAWN BY: GNH
SIZE: D	DRAWING NO: 5XXX	SHEET: 1:1 GND

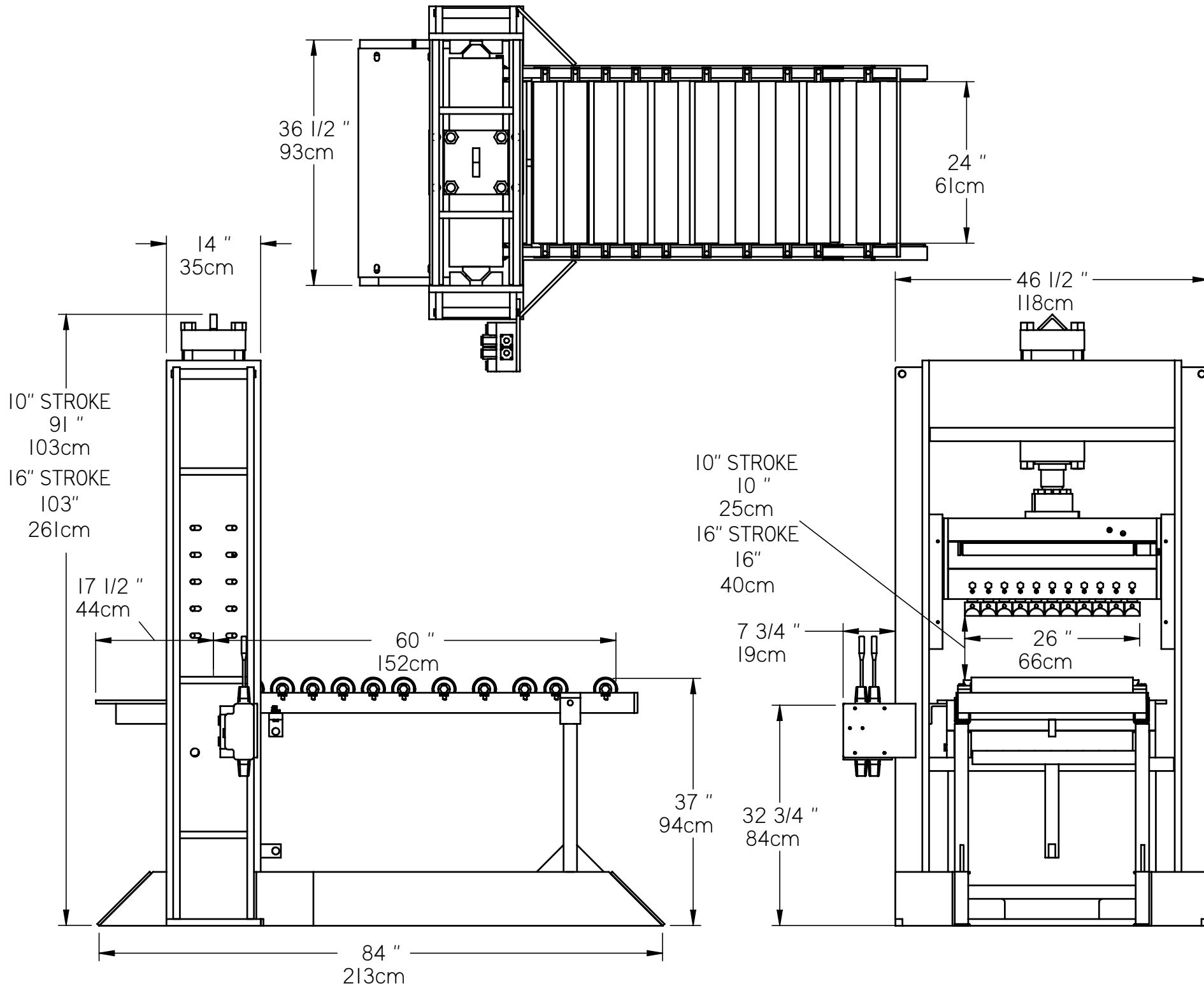

INSTRUCTIONS FOR RE-ADJUSTING THE SIDE GUIDES ON AN HDS CUTTER

- 1.** Level the entire machine with the ground. This will ensure the top jaw is hanging correctly when the guides are loosened.
- 2.** Turn the cutter on and extend the top jaw down as far as it will go. Turn the cutter off afterwards.
- 3.** Loosen all of the Allen head bolts and lock nuts on each side guide. Back off the side guide adjusters from the guides. The guide should be able to move now.
- 4.** Check to make sure the top and bottom teeth are lined up relative to each other. Each top tooth should be centered directly above a bottom tooth. It is important to check this after every step. To do this, look down at the top jaw tooth bar edge and match it up with the bottom jaw teeth. An alternative is to use a mirror to look down the length of the teeth.
- 5.** Wipe each guide bearing surface free of all grease and debris.
- 6.** Slide the two guides on the outbound table side flat against the top jaw.
- 7.** Tighten only the top and bottom bolts on each side guide with only a snug fit. Check alignment per step 4. Tap the top and bottom in to get the top jaw in correct alignment.
- 8.** Slide the other two guides flat against the top jaw and snug down the same two bolts. Check for air spaces between the guides and top jaw. All guides should be contacting the top jaw. The top teeth should still be aligned with the bottom teeth. Readjust as necessary by tapping the guides in.
- 9.** Turn the cutter power on and power up the top jaw until it is flush with the top of the guides. This may push them out some if they are not in alignment. Readjust the guides as necessary by tapping them in.
- 10.** Move the top jaw down until it is in the center of the side guides. Check for tooth alignment and if there are any gaps between the guides. Re-adjust as necessary.
- 11.** Once you are satisfied with the guide fit and jaw alignment, tighten down all of the Allen head bolts and locknuts, wrench tight.
- 12.** Run the top jaw up and down to check for smooth movement. If it sticks or gouges the guides, find the problem area and readjust the guides. Listen to see if the engine is working

harder as the top jaw moves along the guides. This is an indicator of tighter spots between the guides.

- 13.** Once the guides are positioned and the top jaw is able to move smoothly through its' entire stroke, the bolts can be tightened to 150 ft-lbs.
- 14.** The side guide adjusters can finally be screwed in position. They are only used to help keep the guides in position under heavy loads. Screw the bolts in until they are against the guides, finger tight, and then tighten the jam nuts to lock them in position.
- 15.** Check the stroke once again for fluid movement, no gaps between the guides, and alignment of the top and bottom sets of teeth. Once satisfied, thoroughly grease the guides at the zerks.

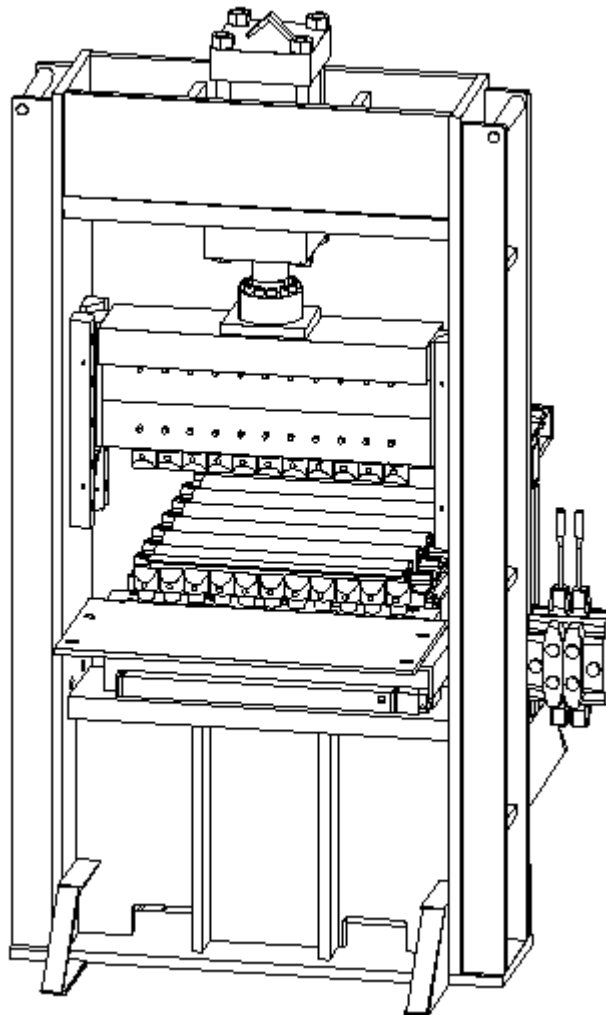

Wiper Seal Installation

- 1) The Wiper seal is located 1/4" from the top of the tooth bar. The tooth will need to be removed from the bar by removing the 5/8" bolt and pulling the tooth out of the hole. Clean any rock and grit from the bar and Extend and lock the teeth before removing the bolts. This will prevent any dirt from getting down into the piston bar holes and scouring the hydraulic cylinder walls. Pry out the old Poly-Pak with a pick or small flat bladed screwdriver. Clean the tooth hole dry rag to remove any old grease.
- 2) Seal Part numbers:
If you have 3" diameter teeth the seal is a Parker 1250-2500 standard Poly-Pak.
If you have 2" diameter teeth the seal is a Parker 1250-1500 standard Poly-Pak.
- 3) The Seal is installed with the O-ring facing out as shown in Detail A of Figure 1.

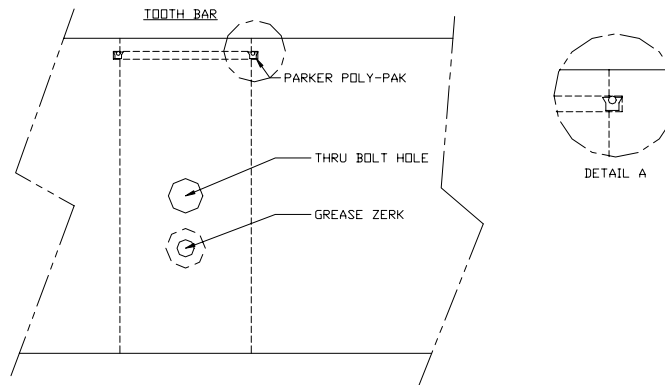
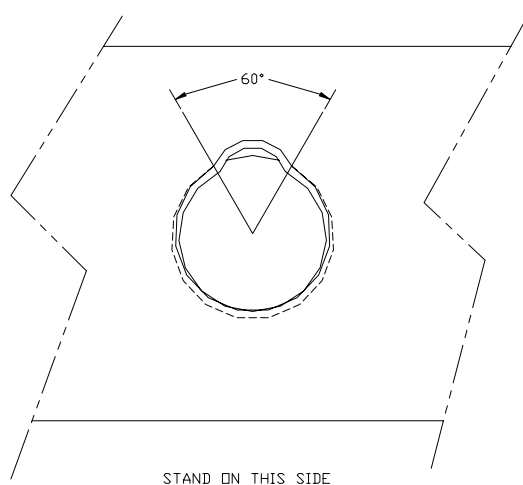
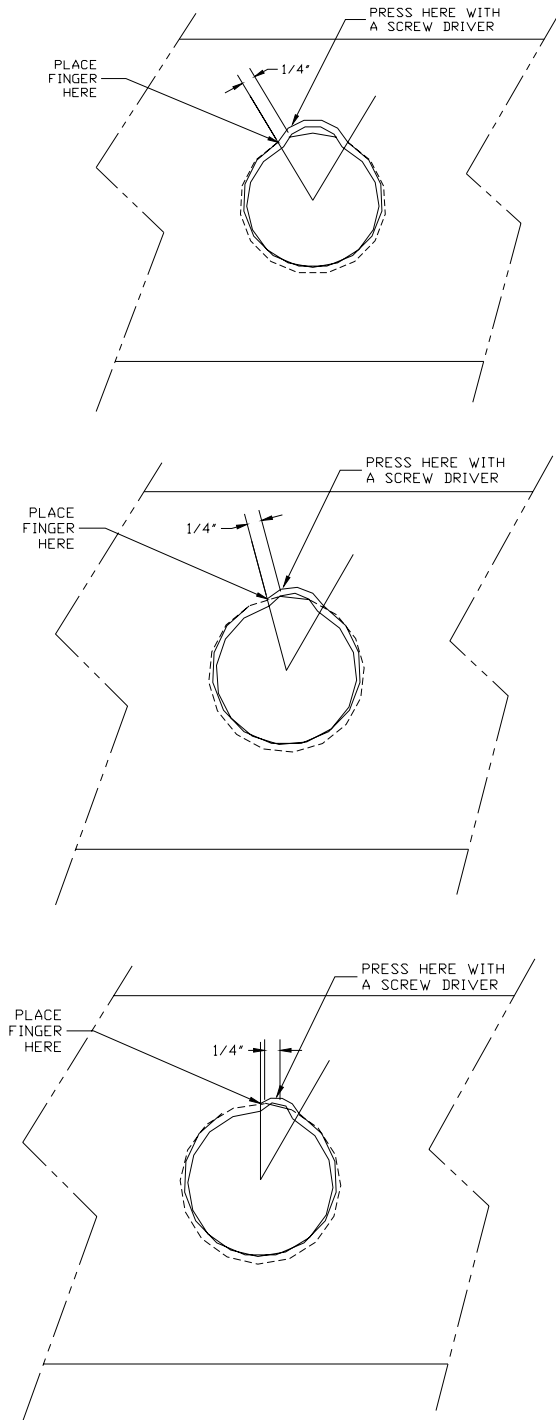

Figure 1

- 4) It will help if the seals are warm, this will make them more flexible. You will also need a small flat bladed screwdriver or some other flat tool with a dull edge so that you don't cut the seal during installation.
- 5) Start by placing the Poly-Pak into the groove leaving a loop as shown in figure 2.



6) Place your finger on one side of the loop and press straight towards the center of the hole with the screw driver about 1/4" away from your finger. Continue to work the seal around in 1/4" increments until it pops into the hole. Check to see if the seal has a roll or a twist in it and adjust it as necessary.



7) Apply some grease to the seal after installation and before reinstalling the tooth into the hole. Make sure the teeth are extended and locked and apply grease to the grease zerk until back pressure is felt at the gun. (15-30 pumps)

Re-Packing the Piston Bar

- 1) The first thing you will want to do is remove the inbound and out bound table. To do this raise the top jaw up as far as it will go and turn off the machine. Remove the clevis pins from the bottom of the hydraulic cylinders on the bottom of the out bound table. Next remove the two pivot bolts located at the point where the in-bound table meets the gravity roller conveyor. This is where the inbound table pivots up and down. Now the table assembly is disconnected from the cutter and using a forklift and some chains the entire table can be lifted through the cutter and set out of the way.
- 2) Turn the cutter back on and extend the teeth but do **not** lock them. Turn the machine back off. If a power washer is available then wash the bottom jaw area. Blow off to dry.
- 3) Remove the 3/4-10 socket head cap screws that secure the bottom tooth bar to the bottom piston bar. You should not have to remove the teeth. These bolts are tight and a large breaker bar may be required.
- 4) Once all of the bolts are removed use a forklift and some nylon straps to lift the tooth bar off of the piston bar and out of the way. (Hint: If you have two 1/2 in diameter rods that are about 1ft long you can remove the bolts from two teeth that are equidistant from the center of the bar and hook the nylon strap on the bars and lift it off.
- 5) Screw a 3/8 bolt into the end of the 2in diameter piston and remove it. Be certain not to get any dirt in the piston bar. Follow the attached instructions to remove the poly-pak and install a new one on the piston.
- 6) Inspect the piston for any gouges or rough area and sand smooth or replace the piston. Also inspect the bore to be certain that it is smooth.
- 7) When the new seal is installed the piston can be reinstalled into the piston bar. This is done by gently pressing the piston into the bore. **DO NOT COCK THE PISTON!! DO NOT USE A HAMMER.** This will damage the piston bar and result in leaks. Be certain the piston stays straight and that the lip on the seal is protected. A small amount of grease may be helpful.
- 8) When all of the pistons are back in place, inspect the tooth bar to be certain that the teeth move freely back and forth. This may be a good opportunity to remove any sticking teeth and clean them, replace any dirt wipers and repair any damaged teeth. Wipe both bars clean and replace the tooth bar. Apply anti-seize to bolts and torque to 250 foot-pounds.
- 9) Replace inbound table being certain that the table springs are back in their seats and reconnect the cylinders.

Call 800-350-9313 with any questions that you might have.

Poly-Pak Removal

- 1) Insert a bolt into the bottom of the piston and place in a vise as shown.
- 2) Take a screw driver and insert it under the Bottom edge and pry the Poly-pak out of the groove. **Be careful not to score the sealing area of the groove (See illustration).** Hold the Poly-pak 90 deg. relative to the placement of the screw driver and work the poly-pak out of the groove.

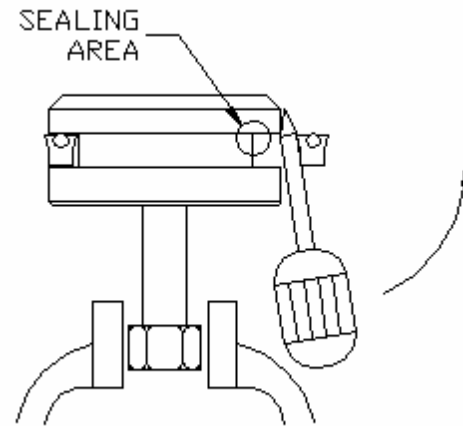
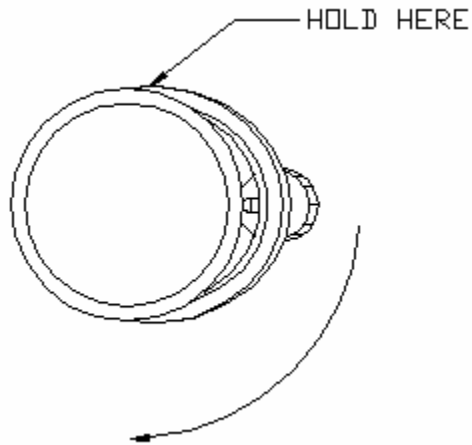

- 3) (Hint: if the Poly-pak is warm it will be easier to remove it. Place it in the sun or heat it with a hair dryer but don't get it too hot or you will warp the piston.)
- 4) Check the piston for nicks and burrs on the edges and polish any scratches that might be in the sealing area with some emery paper.

Poly-Pak Installation

- 1) With the piston in the vise, place Poly-pak the into the groove and start working it onto the piston as shown by arrow #1. Before removing the screw driver, bring it back to the original position as shown by arrow #2. This should prevent the Poly-pak from becoming twisted which would prevent it from sealing correctly. (It may be easier if the Poly-pak is warm. Place it in the sun or heat it with a hair dryer but don't get it too hot or you will warp the piston.)
- 2) Apply some assembly lubricant to the poly-pak before installation. (white lithium or hydraulic oil). Never install a non lubricated poly-pak. Be certain that the "O" ring does not come out of the poly-pak.

