

STONE MASON

MODEL 50

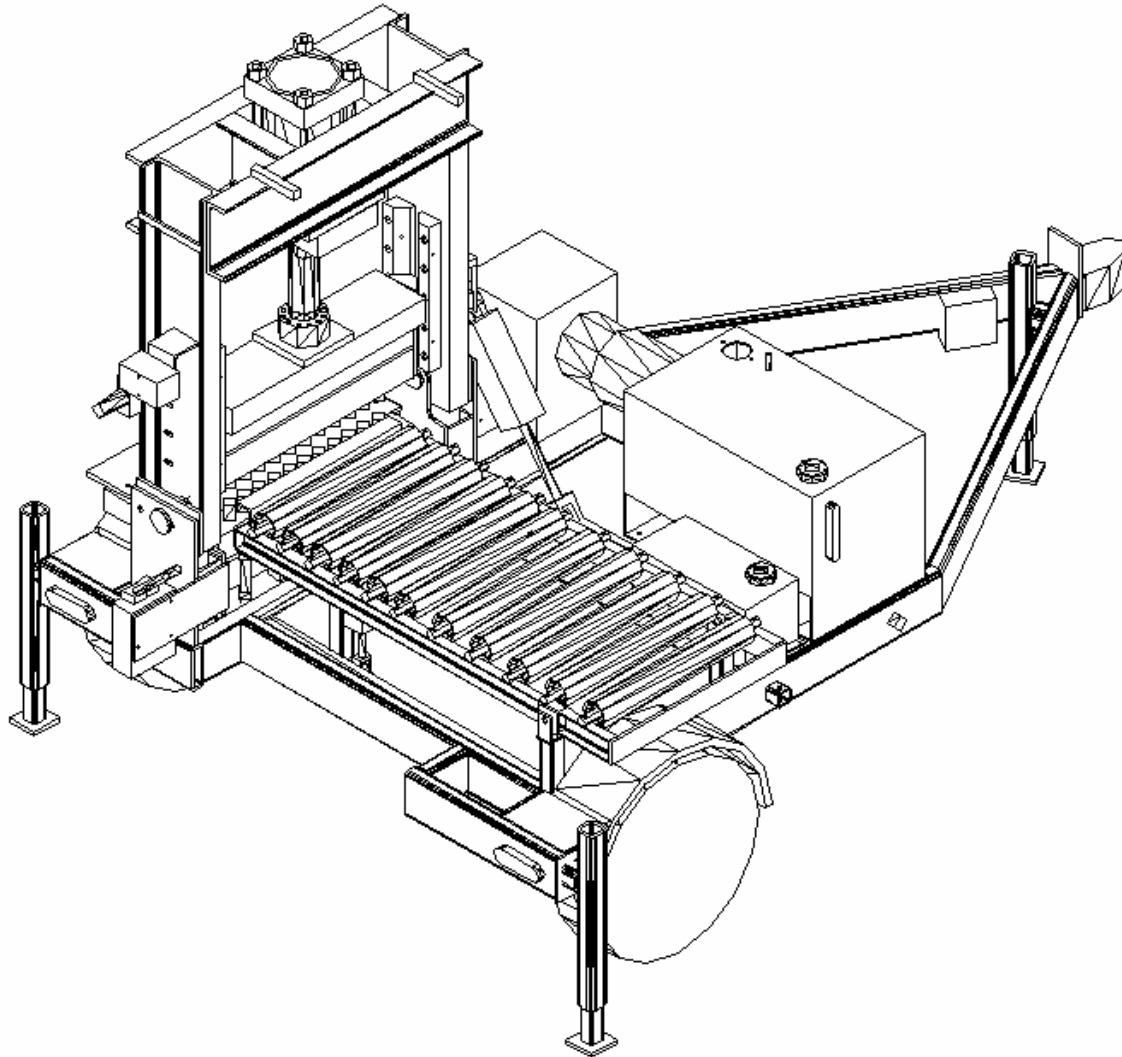

IMPORTANT: Read and understand the entire contents of this manual prior to setting up, operating or maintaining the Stone Mason 50. Special attention should be paid to the safety section as well as the safety highlights located throughout this manual. Contact the factory if you do not understand anything in these instructions.

EDITION I

CEE-JAY TOOL COMPANY
90 DAY LIMITED WARRANTY

For Ninety (90) days from the date of delivery, any part, excluding the carbide inserts in the teeth if applicable, which fails as a result of defective material or workmanship under normal use and service, will be replaced or repaired free of charge when the Stone Mason 50 is located in the 48 continental United States.

This warranty is valid only when products covered by this warranty are installed, used and maintained according to the accompanying written instructions. This warranty does not cover 1) component parts which have been damaged by accident, mishandling or improper use, 2) component parts which have been subjected to negligent operation, 3) damage resulting from improper installation, or 4) damage caused by fire, flood, act of God, earthquake, storm, tornado, or other cause beyond the control of Cee-Jay Tool Company, Inc.

THIS WARRANTY SETS FORTH CEE-JAY TOOL COMPANY'S MAXIMUM LIABILITY FOR THE COVERED STONE SPLITTER. CEE-JAY TOO COMPANY SHALL NOT BE LIABLE FOR SPECIAL, INDIRECT, CONSEQUENTIAL OR INCIDENTAL DAMAGES.

TO RECEIVE WARRANTY SERVICE

Call or write:

Cee-Jay Tool Company, Inc
5100 Boyd Lake Ave.
Loveland, CO 80538

1-800-350-9313
1-970-962-9594
1-970-962-9074 Fax

<http://www.cejaytool.com>

When contacting us concerning warranty information be sure to provide the model and serial number of your Stone Mason 50.

Some states do not allow the exclusion or limitation of incidental or consequential damages, so the above limitation or exclusion may not apply to you. This warranty gives you specific legal rights, and you may also have other rights that will vary from state to state.

TABLE OF CONTENTS

WELCOME LETTER	3
SAFETY GUIDELINES	4
LOCATION	9
LEVELING THE CUTTER	9
GASOLINE ENGINE INSTALLATIONS	10
OPERATING INSTRUCTIONS	11
RAISING THE CUTTER HEAD	11
SPLITTING PROCEDURE	13
FLOW CONTROL VALVE	14
TIPS FOR SPLITTING	14
TOOTH REPLACEMENT	15
CARBIDE REPLACEMENT	15
PREVENTATIVE MAINTENANCE	17
TROUBLE SHOOTING	18

WELCOME

Thank you for your purchase of the Stone Mason 50 stone splitting machine. Cee-Jay Tool Company has been making dimensional stone splitters since 1950 and we congratulate for purchasing one of the best stone splitters available today.

Our basic concept is different from other stone splitter manufactures on the market. We believe in building the strongest, longest lasting machines in the business. Our splitters are fully hydraulic, which means that there are fewer moving parts to wear out with better control over the entire splitting process. Our philosophy is the stone you're splitting should not be tougher than the cutter you're using to split it.

If you have any questions or would just like some additional information about our machines or company, please feel free to contact us at 1-800-350-9313. We look forward to hearing from you and serving your stone splitting needs.

Sincerely,
Cee-Jay Tool Company

NOTICE

This manual and the examples contained herein are provided "as is" and are subject to change without notice. Cee-Jay Tool Company Inc. makes no warranty of any kind with regard to this manual, including, but not limited to the implied warranties of merchantability and fitness for a particular purpose. Cee-Jay Tool Company shall not be liable for any errors or for incidental or consequential damages in connection with the furnishing, performance, or use of this manual or the examples contained herein.

All rights reserved. Reproduction, adaptation, or translation of this manual is prohibited without prior written permission of Cee-Jay Tool Company.

SAFETY GUIDELINES: Cee-Jay Tool Company recognizes that the safe operation of the Stone Mason 50 is the most important responsibility shared by

management and employees. This section of the manual is intended as a guide for those who operate, service and supervise the operation of the Stone Mason 50. It is not intended to be a safety code. Our purpose is to alert operators, service personnel and supervisors to the importance of establishing safe operating and maintenance procedures.

Read and understand these guidelines before attempting to install, operate, or service the Stone Mason 50. Failure to observe these guidelines may cause serious injury or death.

CAUTION
Never move the Stone Mason 50 with the head in the upright position

The Stone Mason 50 is a portable cutter that will fold in half to lower the center of gravity while towing. The unit should never be moved with the top of the machine in the upright position. Failure to fold the machine in half might result in the machine tipping over and causing injury or damage to the towing vehicle.

CAUTION
Never raise the head before the leveling jacks are in place and extended. Never remove the leveling jacks with the head in the upright position.

The trailer is equipped with three leveling jacks. These jacks must be installed and extended to remove weight from the trailer axle to remove any movement due to the trailer's suspension. They should also be in place at any time the head is in the upright position. Failure to comply might result in injury due to the trailer tipping over.

CAUTION
Always operate the machine on flat and level ground.

The Stone Mason 50 is top heavy. Always disconnect the trailer from the vehicle on a flat level surface prior to setting up the machine. Failure to do so could result in injury or damage to the towing vehicle.

CAUTION

Never place your hand or any other part of your body into the splitting area of the Stone Mason 50 unless the main power supply has been disconnected and "Locked and Tagged."

The Stone Mason 50 uses very high pressures to execute a split. This splitting process will severely injure persons who do not recognize this danger. The power unit should be turned off and the power locked and tagged according to OSHA regulations prior to reaching into the jaw area.

Do not let the desire for increased production overcome the essential need for safety. Failure to follow this simple rule can result in serious bodily injury or death.

CAUTION
Never expose any part of the body to a high pressure leak in the hydraulic system.

The hydraulic system is under high pressure and high pressure fluids can be injected into the body if proper precautions are not taken.

CAUTION
Always wear proper protective clothing when operating the Stone Mason 50.

Eye Protection: Splitting stone can produce splinters of stone that can harm the unprotected eye. All personnel operating or working near the Stone Mason 50 should wear safety glasses with side shields. Some stone splits with a force that warrants additional protective measures such as full face shields.

Hand Protection: The splitting process can produce a number of razor sharp edges that can seriously injure the unprotected hand. All operators should wear a good pair of protective gloves.

Foot Protection: Whenever split stone is handled, the risk of a serious foot injury exists. Safety- toe shoes should be worn by all operators to protect against falling stone.

Ear Protection: Hearing protection may be necessary depending on the power unit as well as the work environment,. Contact your local health official for specifics on required levels of hearing protection.

CAUTION

The Stone Mason 50 as well as the area around it should be kept free of debris at all times.

The Stone Mason 50 can produce a large amount of debris in the course of a day, both on the machine and around the machine. Some means should be devised to remove the stone chips from the area.

The rollers and splitting area should be kept clear of stone fragments at all times. We recommend using a broom or long handled brush to remove stone fragments from the tooth area. Do not remove these fragments with your hands without first turning off the power unit. Operating the Stone Mason 50 with stone fragments piled up under the teeth can result in machine damage or personal injury.

The area around the Stone Mason 50 should be kept clear to reduce the risk of tripping.

CAUTION

Never remove or deface any placard or decal that instructs the operator or others of safety precautions.

The Stone Mason 50 was shipped from the factory with certain warning placards in place. These placards provide information critical to the safe and efficient operation of the splitter and should not be removed, covered or defaced. If replacement signs are needed, contact the factory.

CAUTION

Inspect all hydraulic hoses and connections daily for leaks or damage.

The hydraulic system is designed for up to 2000 psi of operating pressure. When a leak occurs with fluids under this kind of pressure, as serious hazard exists. All worn or damaged fittings and hoses should be replaced immediately.

CAUTION

Always stand away from the inbound table while raising and lowering the head

In the event of a hydraulic system failure while raising or lowering the head the head of the machine may fall onto the inbound table. Make sure that no one gets pinned under the head of the machine in this unlikely event.

DANGER

The hydraulic system must be purged of air after the system has been serviced in any way. The head of the machine may not be restrained by the hydraulic cylinder.

The Stone Mason 50 uses a hydraulic cylinder to raise and lower the head of the machine. If air gets into this cylinder the cylinder will not restrain the head of the machine while it is being lowered and the head will come crashing down on the inbound table. To prevent this disconnect the cylinder from the pin mounts and cycle it to full stroke in both directions to purge the system of any air.

CAUTION

Only qualified technicians should be allowed to make adjustments to or perform service on the hydraulic system.

The Stone Mason 50 has been shipped from the factory with the pressure relief valves set for optimal operation. Altering these adjustments can severely damage the splitter and or cause serious bodily injury. Altering the pressure settings on the pressure relief valves will void the manufacturers warranty.

CAUTION

Improper lifting or moving of this equipment can result in personal injury and equipment damage.

The Stone Mason 50 is top heavy and prone to tip over if caution is not exercised whenever the splitter is moved. The top jaw should be raised as far as it will go whenever the splitter is moved and the top head lowered onto the inbound roller table.

When moving the splitter using the available towing package be sure to use a vehicle capable of safely handling the tongue weight of the splitter. The electric brakes should always be connected prior to towing the splitter.

Arrangements can be made to have a factory representative come to your site and assist in setting the machine up and training personnel in the proper use of the splitter.

If at any time you encounter problems or have questions please contact the factory directly at 1-800-350-9313.

LOCATION: Before your Stone Mason 50 is set up at your job site, how and where it will be positioned should be determined.

Permanent Installation: The Stone Mason 50 will be placed in a permanent location and the stone will always be brought to the splitter. A level reinforced concrete pad or foundation capable of supporting about 10000 pounds should be designed and constructed. It may be desirable to have concrete pads under each of the legs of any additional conveyors as well.

CAUTION
Position the Stone Mason 50 on a hard level surface as it is top heavy and prone to tipping over.

Mobile Installation: The Stone Mason 50 will be moved frequently from place to place.. Always locate the Stone Mason 50 on a hard level surface. Always disconnect it from the towing vehicle and extend all three of the leveling jacks to remove any movement due to the trailers suspension .

CAUTION
An excessive slope on the inbound conveyor could cause stone to roll in an uncontrolled manner causing equipment damage or serious personal injury.

LEVELING THE CUTTER: Once the Stone Mason 50 has been moved into position it will be necessary to level the machine. Always disconnect the trailer from the towing vehicle before raising the head. Remove the 2 leveling jacks from the side of the trailer and place them behind the rear wheels on the jack lugs provided. The 2 jack lugs on the side of the trailer are intended to transport the leveling jacks only. Do not use them to level the trailer, it may cause the trailer to be unstable. Extend all three jacks to remove enough weight off of the axle so that the suspension of the trailer has no effect.

GASOLINE ENGINE INSTALLATIONS: If a gasoline or diesel engine powers the hydraulic power unit it will be necessary to fill the fuel reservoir. Consult the literature provided for your specific engine to review specific starting, break in and maintenance procedures.

CAUTION

Never remove any guards or enclosures while the engine is running. Moving parts can cause serious injury.

CAUTION

Never add fuel to a running engine. Hot engine surfaces and sparks produced from the engine are possible sources of ignition.

CAUTION

Never service the engine when the splitter is operating.

CAUTION

If an engine is used in an enclosed area some means of exhausting the engine will be necessary. Inhalation of exhaust gases will result in serious illness or death.

CAUTION

Hot exhaust surfaces may cause personal injury.

OPERATING INSTRUCTIONS: Be sure to read the section on safety prior to operating the Stone Mason 50. Before starting the hydraulic power pack be sure to check all fluid levels. The oil sight gage on the side of the hydraulic tank has a black mark near the top and a red mark near the bottom. The oil level in the tank should remain between these two lines at all times. The unit is powered by a gas engine be sure to check the engine oil level using the dipstick located on the right side of the engine.

Start the power pack by following the start up procedures in the manual for your specific engine. Let the pump circulate the hydraulic oil for a few minutes prior to operating the splitter.

CAUTION:
The working parts of the hydraulic power pack may get hot when in use. DO NOT TOUCH.

RAISING THE CUTTING HEAD: Remove the retaining pins from the slots in the head of the machine. Start engine and let it warm up to operating temperature. Make sure that no one is standing around the head of the machine while raising or lower the head of the machine. Pull handle #3 up to raise the head of the machine until it reaches the head travel stop and reinsert the retaining pins. You are now ready to split some stone. (Reverse the procedure for head lowering)

CAUTION:
Never operate the splitter with out the locking pins in place.

Always make sure that the locking pins are in place before operating the splitter. The 3” diameter cylinder is used to raise and lower the head only, it is not intended to hold the head in the upright position. The 8” diameter cylinder will produce more force than the 3” diameter can withstand. Machine damage will certainly occur. Always replace the pins back into the holes when the head is lowered so that they will not get lost.

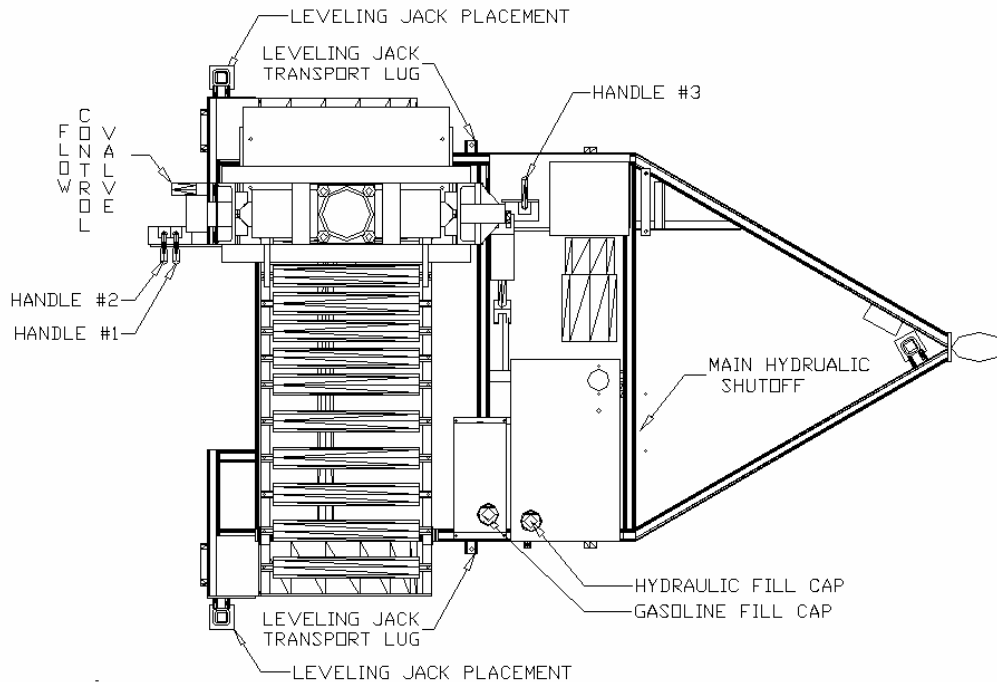

The control valve operates as follows (Fig.1):

Handle #1 Up	Raises upper jaw.
Handle #1 Down	Lowers upper jaw.
Handle #2 Up	Raises in bound table, extends upper and lower teeth
Handle #2 Down	Locks teeth in place
Handle #3 Up	Lift head up.
Handle #3 Down	Lower Head down.

Handle #2 has a detent in the Up position, which means it will remain in this position until it is return to the neutral position.

SPLITTING PROCEDURE: The following steps are the general steps taken to split stone. These steps may vary depending upon the stone and the experience of the operator.

CAUTION:
Always wear safety glasses and protective clothing to protect against splintering stone.

- 1- Raise the upper jaw far enough to get the stone into the machine. (Handle #1 Up)
- 2- Extend the teeth and raise the inbound table. (Handle #2 Up and detented)
- 3- Insert the stone to the desired depth while keeping the inbound table raised. If the control valve is equipped with a detent kit then the inbound table will remain raised until the handle is pulled to the neutral position. If the operator does not want to engage the detent feature of the valve then do not push the handle all the way forward. In this case the handle will return to the neutral position as soon as the operator lets go of the handle and the inbound table will return to the lower position. Always raise the inbound table prior to moving the stone into the splitter so as to prevent the stone from dragging across the bottom teeth. The carbide (if applicable) or edge of the lower teeth will show premature wear if the stone is allowed to drag across them.
- 4- Release Handle #2 used in step 3 to return the in-bound table to the lower position. If the detent feature was used then the operator will need to manually pull back on the lever to return it to the neutral position.
- 5- Pull Handle #1 down to lower the upper jaw until all of the teeth come into contact with the stone. The upper and lower teeth will retract into the upper and lower jaws as the upper jaw is lowered onto the stone. Do not allow any of the teeth to be pushed all the way into the upper or lower jaw. Always leave at least 1/8 inch of clearance between the head of the tooth and the jaw.
- 6- Lock the teeth in place by pulling handle #2 down. Handle #2 will return to the neutral position. (It is not detented.)

CAUTION:

Failure to lock the teeth in place prior to splitting the stone will seriously damage the splitter.

7- Pull Handle #1 down to bring the upper jaw down to split the stone. Start at step one to begin the next split.

It sounds a little complicated at first but eventually you will see that there is a rhythm to the cutting procedure:

Handle #1 Up, Handle #2 Up, Handle #1 Down, Handle #2 Down, Handle #1 Down .

FLOW CONTROL VALVE: The flow return valve pictured in Fig. 1 regulates the rate of flow of the hydraulic oil back to the hydraulic tank for the inbound table which in turn regulates the speed which it returns to the neutral position. The oil supporting each tooth also flows through this valve when the teeth are being pushed up into the jaw beam during the equalization cycle. This valve also allows the operator to adjust the splitter to account for different viscosity's of hydraulic oil. **Do NOT close this valve all the way.**

TIPS FOR SPLITTING: Every type of stone splits differently and experience is the best teacher. We can only offer general guidelines for stone splitting.

- Whenever possible try to split with the grain of the stone. Although it is possible to split against the grain, the best split quality is obtained when splitting with the grain.
- Remove loose rock and other debris from the stone prior to splitting. Loose layers of stone stacked on top of each other will not split properly.
- Bring the top jaw down on the stone so that as many teeth as possible are in contact with the stone.
- Place the flat side down. Although both the top and bottom teeth will equalize one inch, placing the flat side down makes it easier to ensure that as many teeth as possible are in contact with the stone because the top jaw can be seen by the operator. Placing the flat side down also makes it easier to roll the stone on the conveyors.
- To improve efficiency only move the upper jaw up as far as is needed to get the next piece of stone into the Stone Mason 50 to be split. Moving the upper jaw too far up can be a waste of time.

- When splitting fieldstone or other irregular shaped stone, let the teeth equalize up into the jaw beam as far a possible. This will help support the teeth on difficult splits.
- When splitting thin or weak stone, do not lower the top jaw onto the stone at full speed. The stone will most likely break before the split is made. To avoid this, bring the top jaw down onto the stone slowly by letting up on the control lever.

TOOTH REPLACEMENT: It may become necessary to replace a tooth at some time. The following will describe the necessary steps.

- 1- Thoroughly clean the area around the tooth that is to be removed.
- 2- Raise the top jaw up at least 8 inches from the bottom position.
- 3- Remove the retaining bolt located directly inline with the tooth that is to be removed.
- 4- Slide the tooth out of the jaw beam.
- 5- Examine the wiper inside the jaw beam and replace it if it is worn.
- 6- Wipe out the top portion of the tooth hole down to the wiper.
- 7- Clean the replacement tooth making sure there is no debris on the shank of the tooth.
- 8- Insert the replacement tooth into the hole in the jaw beam. In temperatures below 40 degrees Fahrenheit it may be difficult getting the tooth past the wiper. Be sure the new tooth lines up with the other teeth.
- 9- Replace the retaining bolt and torque the top lock nut to 90 ft-lbs.
- 10- Extend the teeth and lock them
- 11- Grease the new tooth prior to using.

CARBIDE REPLACEMENT (if applicable): The carbide inserts in each of the teeth is replaceable. The carbide edge will wear with time and can be sharpened several times before it needs to be replaced. The teeth in the center of the bottom jaw will wear the fastest depending on the type of stone being split. Since the teeth are interchangeable, once the center teeth become dull they can be traded with the outside top jaw teeth, which do not wear as quickly as the bottom teeth. Once the carbide has

worn to the point that it cannot be sharpened anymore or the carbide has fractured, then the replacement process is as follows:

- 1- Follow the steps in the section “Tooth Replacement” to remove the tooth from the tooth bar.
- 2- Heat the tooth to about 350 degrees Fahrenheit to release the carbide from the epoxy. Do NOT use an acetylene torch or other means that will heat the tooth up too much. Do not turn the steel red-hot, as this will destroy the temper on the tooth.
- 3- Once the tooth has been heated the carbide can be removed from the tooth with a screwdriver or other suitable tool.
- 4- The old epoxy must be removed from the seat before replacing it. This can be done with a grinder or by sand blasting. If a grinder is used do not grind into the steel and deform the seat. If sand blasting is used be sure to protect the shaft of the tooth from damage.
- 5- Wipe the seat clean with some kind of solvent.
- 6- Check to be certain that the carbide insert fits firmly into the bottom of the seat. If it does not it may be necessary to grind the carbide until it does fit against the bottom of the seat.
- 7- Once the seat has been thoroughly cleaned and the carbide fits into the seat properly then mix the two-part epoxy according to the instructions on the container.
- 8- Fill the seat with epoxy and coat the three sides of the carbide with epoxy.
- 9- Press the carbide into the seat until the carbide comes in contact with the bottom of the seat.
- 10- Be sure the carbide is centered from side to side in the tooth and wipe away any excess epoxy from the tooth.
- 11- Let the epoxy cure according to the instructions on the package.
- 12- Follow the steps in the section “Tooth Replacement” to reinstall the tooth.

PREVENTATIVE MAINTENANCE: Proper maintenance will extend the life of the Stone Mason 50 and result in lower overall operating costs. The following chart describes recommended maintenance items and intervals:

Greasing the teeth is the single most important maintenance on the Stone Mason 50. **Prior to greasing the teeth, extend and lock them.** The grease lubricates the teeth and helps prevent sand and other abrasive material from getting into the jaw. Failure to grease the teeth will damage the splitter and void the manufacturers warranty. Wipe away any excess grease to avoid getting the grease on any stone product.

The hydraulic system has a return line filter in the tank. Use replacement element number LHA (TIE16-25-1) or equivalent.

If additional hydraulic oil is needed use Conoco Super Hydraulic Oil 32 or some other equivalent ISO Grade 32 hydraulic oil.

Refer to the following chart for maintenance items and intervals.

Interval	Item	Quantity
Daily	Check hydraulic oil level	1
Daily	Check engine coolant level	1
Daily	Inspect all hydraulic hoses & fittings for leaks	-
Daily	Check engine oil level	1
Daily	Grease the teeth	22
Daily	Cleanliness around jaws and teeth	-
Daily	Check for cracked or broken carbide (if applicable)	36
Weekly	Air cleaner on engine	1
Weekly	Brass filter on bottom of in bound table cylinders	2
Weekly	Grease the side guides	8
Semi-Annual	Condition of the hydraulic oil	-
Semi-Annual	Overall condition of the hydraulic system and filter	-
Semi-Annual	Fuel filter	1

TROUBLESHOOTING:

Situation	Reason	Solution
The inbound table will not lift the larger pieces of stone above the bottom teeth.	The flow control valve is open too far and not allowing enough pressure to build up in the hydraulic system to create enough force to lift the stone.	Close the flow control valve until the inbound table will lift the stone above the bottom teeth.
On the extend teeth cycle, the teeth extending too slowly.	The flow control valve is open too far and allowing too much oil to return back to the tank.	Close the flow control valve until the teeth extend at an acceptable speed.
When the hydraulic oil heats up, the inbound table gets weaker .	The viscosity of the oil goes up with temperature.	Close the flow control valve until the situation is corrected.
When cutting thin or weak stone, the stone breaks before the teeth fully equalize.	The flow control valve is closed too far and not allowing the oil to return from the teeth back to the tank	Open the flow control valve up until the teeth equalize without breaking the stone. refer to "Tips for splitting"
When the hydraulic oil is cold, the teeth seem to be stiff and do not equalize as easily as when the oil is warm.	The viscosity of the oil goes down with temperature.	Open the flow control valve up to allow the lower viscosity oil to return to the tank.
The inbound table stays in the up position and does not lower during the split cycle	The flow control valve is closed too far and not allowing the oil to return back to the tank	Open the flow control valve up to allow the inbound table to return to the neutral position.
A tooth is stuck and will not extend after a cut is made.	The tooth bar needs to be cleaned and greased more often to prevent contamination	Close the flow control valve all the way and extend the teeth. Then reopen the control valve to it's previous setting