

CARBIDE INSTALLATION

- 1) Remove any of the carbide remaining in the tooth by heating it with a torch to break the bond of the glue. Do not over heat the tooth because this will remove the temper on the tooth and cause it to develop stress cracks and break. This will only take a few minutes.
- 2) Remove any glue from the corners of the groove with a file, a wire brush, etc. We sand blast the groove. Any remaining material will cause a weak bond and point loading on the carbide which will either cause the carbide to fracture or fall out.
- 3) The bottom edge of the carbide should be rounded slightly to reduce the chance of point loading. This

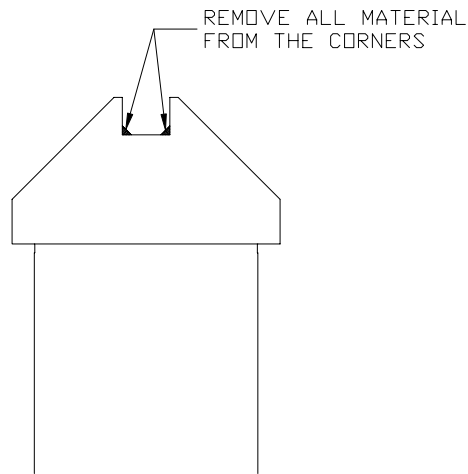

can be done on a grinder with a green wheel installed. (Green wheel stones are used to grind carbide.) Cee-Jay Tool Company sends out carbide pre-ground.

- 4) Roughen the groove with sandpaper and remove any grease and rust with Acetone.

TEMPERATURE FOR STEP 5 IS VERY IMPORTANT. IF THE TOOTH HAS ANY "COLD FEEL" TO IT, AT CEE-JAY TOOL WE RUN HOT WATER ON THE TOOTH TO MAKE SURE THE EPOXY IS GOING TO WORK WELL.

- 5) Mix the 2 part JB Weld thoroughly. Spread the epoxy on the bottom and sides of both the carbide and the tooth groove, and let it cure under medium clamping pressure for a minimum of 15 hours (24 hours is preferred) in a heated area no less than 55° F.

